



STATE OF WASHINGTON
DEPARTMENT OF ECOLOGY

PO Box 47600 • Olympia, WA 98504-7600 • 360-407-6000

711 for Washington Relay Service • Persons with a speech disability can call 877-833-6341

May 26, 2021

Kevin J. McKee, P.E.
Porous Technologies, LLC
163 Thadeus Street
South Portland, ME 04106

RE: Porous Technologies, LLC Urban Raingarden Stormwater Runoff Filtration

Dear Mr. McKee:

The Washington State Department of Ecology (Ecology) finds the Porous Technologies, LLC Urban Raingarden systems are functionally equivalent to a bioretention planter and planter box when used for treating stormwater. The media specifications for the Porous Technologies, LLC Urban Raingarden systems must adhere to the guidelines for Bioretention areas, found in BMP T7.30 in the 2019 Stormwater Management Manual for Western Washington (SWMMWW) or BMP T5.31 in the 2019 Stormwater Management Manual for Eastern Washington (SWMMEW). The sizing procedure must also adhere to the procedure outlined in the Bioretention area of the manual mentioned above.

Contractors may use the Porous Technologies, LLC Urban Raingarden system at project sites without seeking additional Ecology approval. Ecology cannot endorse this product or its manufacturer. You must follow manufacturer installation recommendations.

For more information, contact Douglas C. Howie, P.E. at douglas.howie@ecy.wa.gov or (360) 407-6444.

Sincerely

Douglas C. Howie, P.E.
Stormwater Engineer
Program Development Services
Water Quality Program

cc: Carla Milesi, TAPE Technical Lead, Washington Stormwater Center



April 28, 2021

Douglas C. Howie, PE
Department of Ecology
State of Washington
300 Desmond Drive SE,
Lacey, WA 98503

Re: Porous Technologies, LLC Urban RainGarden & WA DOE V-5.15 Bioretention Planter

Dear Mr. Howie,

Attached is a brochure and standard details for the Urban RainGarden™ System recently developed by Porous Technologies, LLC. The Urban RainGarden™ has been designed to serve as a precast concrete host structure for a typical bioretention planter. The Urban RainGarden™ is proposed for use in developed, urban areas where the expediency and convenience of working with precast concrete is valued.

We reviewed the Item; BMP V5.15: Bioretention Planter, as described in the 2019 Stormwater Management Manual for Western Washington (2019 SWMMWW) to gain an appreciation as to whether the Urban RainGarden™ would be considered a functional equivalent to that BMP.

We believe that the functions and features provided by the Urban RainGarden™ will meet the requirements for the Figure V-5.15 Bioretention Planter.

The Urban RainGarden will be designed in accordance with the Applications and Limitations, Infeasibility Criteria and General Design Criteria as published in the 2019 SWMMWW.

The Urban RainGarden™ will meet the specific 2019 SWMMWW physical Bioretention Planter Design Criteria as follows:

Flow Entrance and Presettling

Each Urban RainGarden™ shall be specifically designed to limit flow velocities entering the system to less than 1.0 ft./sec. At each 18" minimum width entrance to an Urban RainGarden™ rounded river rock will be placed to dissipate energy. There will be a minimum drop of 2-3 inches into the Urban RainGarden™ from the gutter line and an area for settling and debris removal.



Bottom Area and Side Slopes

Maximum planted side slope if total Urban RainGarden™ depth is greater than 3 feet shall be no more than 3H:1V.

Flow depths and velocities shall be carefully considered with check dams provide as necessary to prevent erosion.

A minimum shoulder width of 12” shall be provided between any Urban RainGarden installations and the road and compaction of backfill materials in that space shall be to 90% Proctor.

Ponding Area

The maximum ponding depth provided in an Urban RainGarden™ shall be 12 inches and all systems shall be designed to drawdown the surface pool in 24 hours.

Soil Depth

The Urban RainGarden™ shall have a bioretention soil mix depth of 18 inches.

Filter Fabric

Filter fabrics will not be used between the subgrade and the bioretention soil mix.

Underdrain

Optional underdrains will be provided when the underlying soils meet the conditions proscribed by the 2019 SWMMWW and shall be designed and installed using the materials, and in the manner described, in the manual.

Check Dams and Weirs

The Urban RainGarden™ shall be designed to include our porous concrete “Garden Baffle™”. Urban RainGardens™ shall match the longitudinal slope of the adjacent roadway and the Garden Baffles™ shall be placed to increase detention time and infiltration capacity.

In every other way, including the use of a UIC Discharge, Hydraulic Restriction Layer, Plant Materials used and the Mulch Layer, the design of the Urban RainGarden™ System will mimic that of the 2019 SWMMWW defined V-5.15 Bioretention Planter.

The hydraulic design of the Urban RainGarden™ will follow the procedure described in the 2019 SWMMWW as “Runoff Model Representation”.

Only State of Washington, Department of Ecology approved bioretention soil mixes will be used in Urban RainGardens™ proposed for use in Western Washington.

Construction of the Urban RainGarden will follow our “Manufacturer Handling and Installation Guidelines” and the Installation Criteria specified in the 2019 SWMMWW.

It is also intended that any Urban RainGarden™ applications in Western Washington would comply with the Maintenance requirements that are outlined in the 2019 SWMMWW.

Porous Technologies, LLC will be marketing the Urban RainGarden™ as a precast host for bioretention areas in markets nationally. We would like to market the system in Western Washington as a functional equivalent to the WA DOE V-5.15 Bioretention Planter. Each individual Urban RainGarden™ design would be reviewed by Porous Technologies, LLC representatives to ensure that the design is in conformance with the WA DOE V-5.15 Bioretention Planter design goals.

After a review of the 2019 SWMMWW and in consideration of the reasons stated above we believe that the Urban RainGarden™ is a functional equivalent to the WA DOE V-5.15 Bioretention Planter.

We respectfully request that you evaluate the information that led to this conclusion and let us know if you agree. If you need any additional information in your review of this matter, please do not hesitate to contact me.

Sincerely,
Porous Technologies, LLC

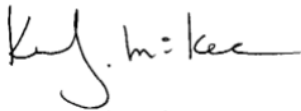
A handwritten signature in black ink that reads "Kevin J. McKee". The signature is written in a cursive style with a large initial "K" and "M".

Kevin J. McKee, PE*
*(CT, MA, ME)

enc.

OPTIONAL PRECAST POROUS CONCRETE BAFFLE WALL
(TYP. - HEIGHT AND LOCATION VARIES BASED ON
SYSTEM SLOPE AND TREATMENT OBJECTIVES)

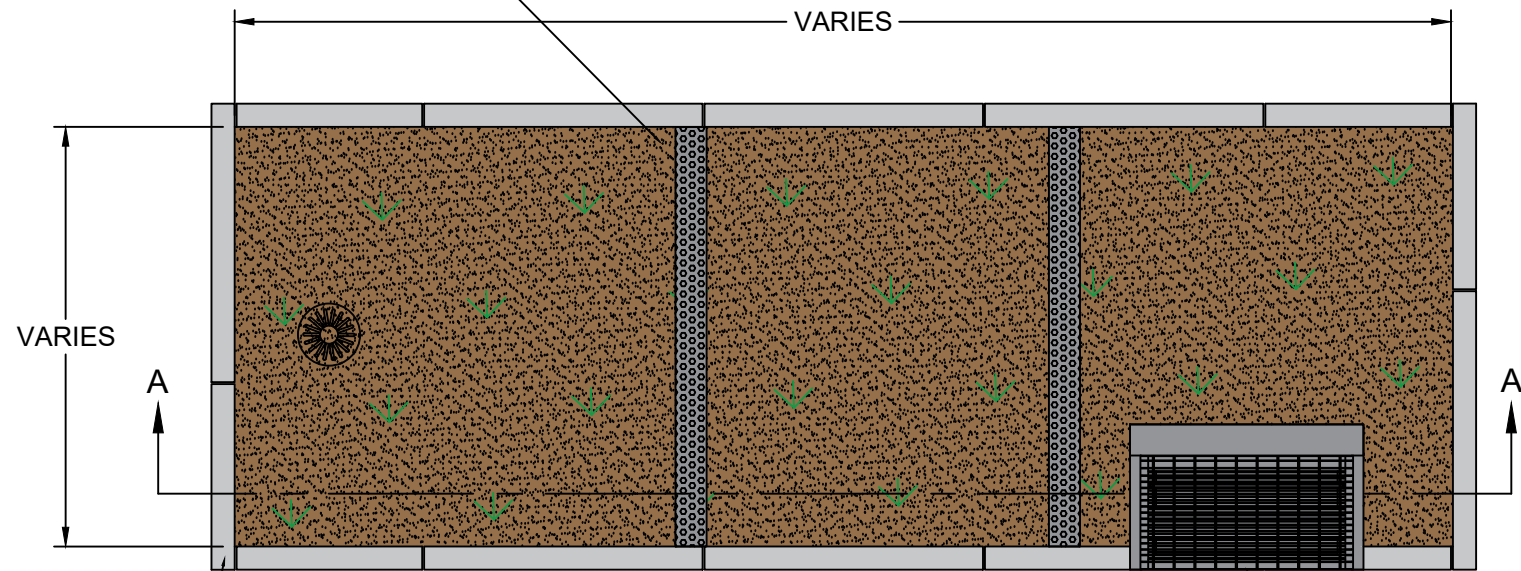

PLAN VIEW

INLET
(TYPE AND
LOCATION VARIES)

PLANTER CORNER
STATION
ELEVATION
(TYP. LABELING FOR EACH CORNER)

48" WALL LENGTH AVAILABLE (TYP.)

72" WALL LENGTH AVAILABLE (TYP.)

PERFORATED UNDERDRAIN
(LOCATION/DEPTH VARIES)

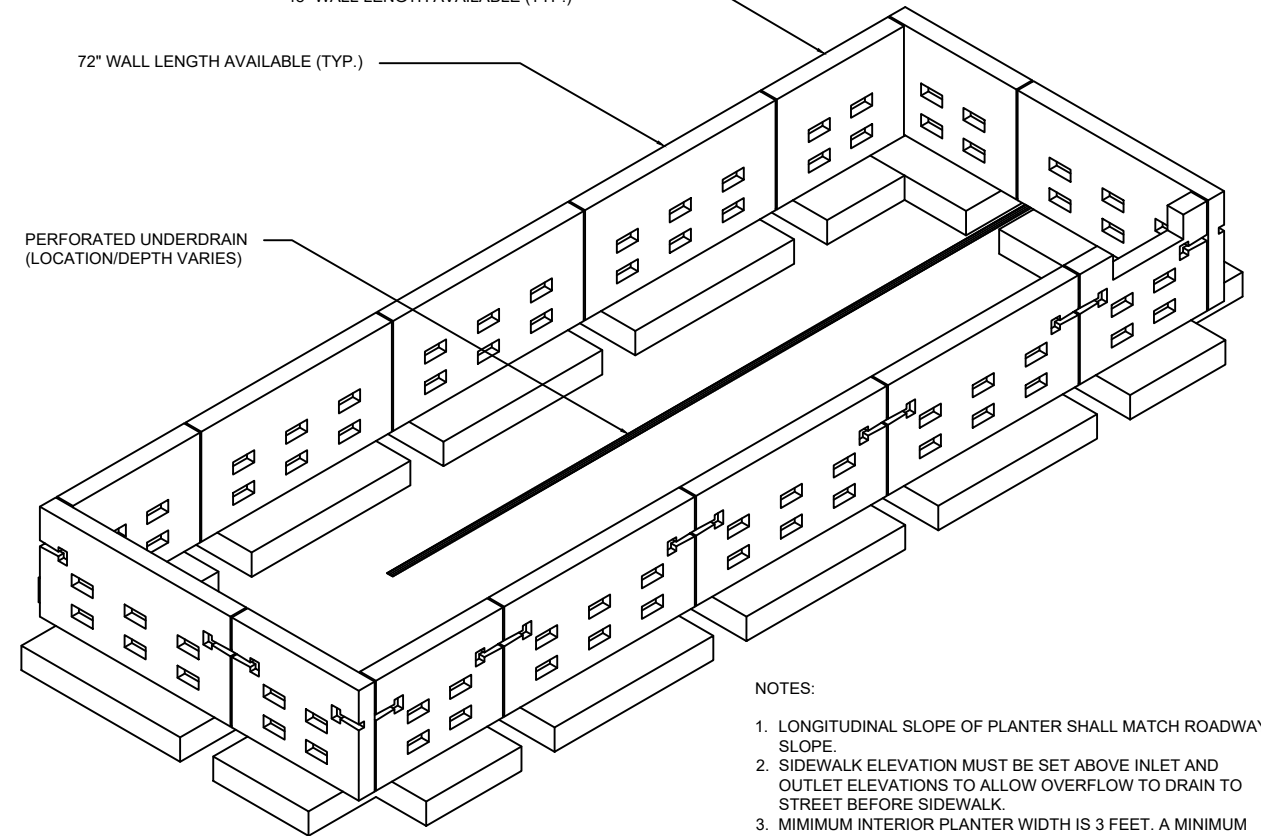

ISO VIEW

NOTES:

1. LONGITUDINAL SLOPE OF PLANTER SHALL MATCH ROADWAY SLOPE.
2. SIDEWALK ELEVATION MUST BE SET ABOVE INLET AND OUTLET ELEVATIONS TO ALLOW OVERFLOW TO DRAIN TO STREET BEFORE SIDEWALK.
3. MINIMUM INTERIOR PLANTER WIDTH IS 3 FEET. A MINIMUM OF 4 FEET INTERIOR PLANTER WIDTH IS REQUIRED FOR STREET TREES.
4. EXISTING UTILITY LINES MUST BE SLEEVED OR RELOCATED. PROPOSED UTILITY LINES TO BE LOCATED OUT OF THE PLANTER.
5. AREA AND DEPTH OF PLANTER ARE BASED UPON ENGINEERING CALCULATIONS AND RIGHT OF WAY CONSTRAINTS.
6. MAXIMUM PLANTED SIDE SLOPE IF TOTAL URBAN RAINGARDEN™ DEPTH IS GREATER THAN 3 FEET SHALL BE NO MORE THAN 3H:1V.
7. URBAN RAINGARDEN DESIGN SHALL BE REVIEWED BY POROUS TECHNOLOGIES, LLC STAFF TO ENSURE CONFORMANCE WITH LOCAL REGULATORY AND MANUFACTURER'S REQUIREMENTS.

OPTIONAL BEEHIVE OUTLET
WITH OPTIONAL FILTER
(SIZE AND LOCATION VARIES)

PRECAST CONCRETE
SIDEWALL

ALUMINUM ANGLE BRACKET
(TYP.)

HARDWOOD MULCH
BY OTHERS

LOCALLY APPROVED
BIOFILTRATION SOIL MEDIA

ASSHTO NO. 57 STONE

PERFORATED UNDERDRAIN PIPE
(LOCATION/DEPTH VARIES)

OPTIONAL PRECAST POROUS CONCRETE BAFFLE WALL
(TYP. - HEIGHT AND LOCATION VARIES BASED ON
SYSTEM SLOPE AND TREATMENT OBJECTIVES)

PRETREATMENT INLET STRUCTURE
(TYPE AND LOCATION VARIES)

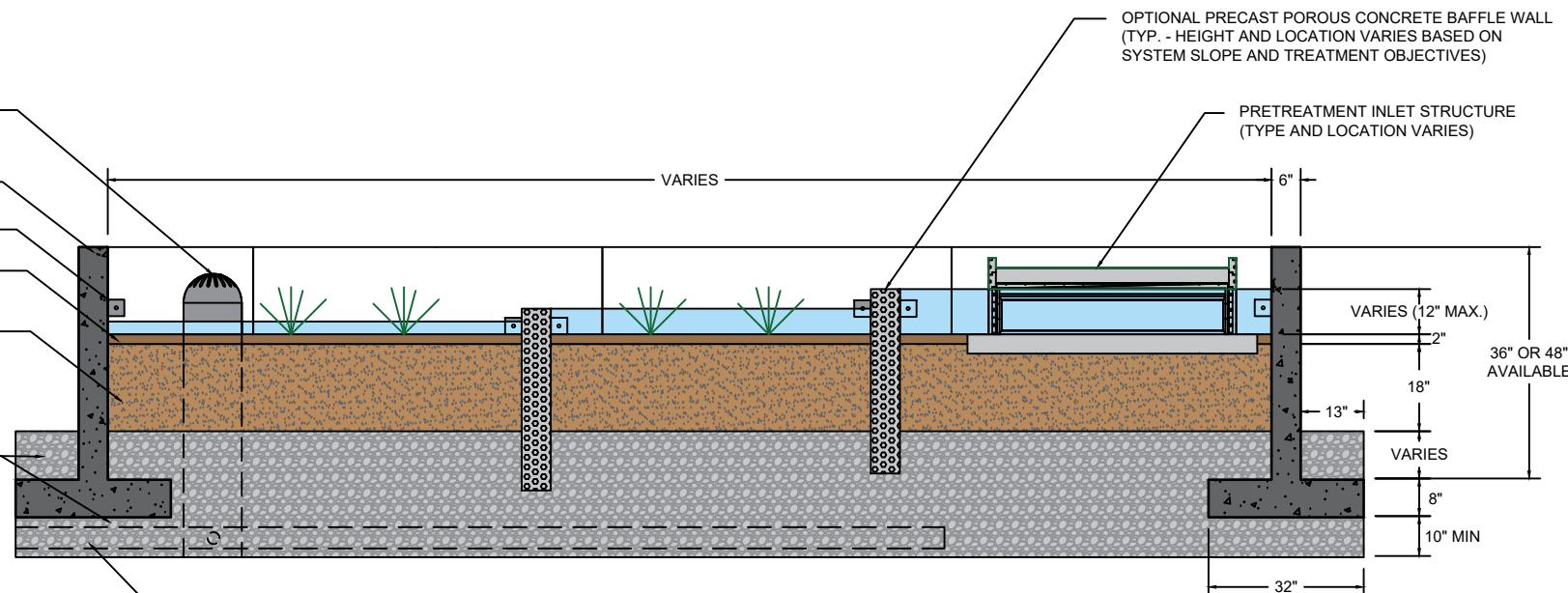

SECTION A-A



888.357.1161
www.stormcrete.com
Porous Technologies, LLC
163 Thadus Street
South Portland, ME 04106
STORMCRETE® PATENT PENDING

URBAN RAINGARDEN

DATE: 04/26/2021
DRAWN BY: TJC
CHECKED BY: KJM
SCALE: NTS

GENERAL DETAIL

DWG NO.
D1

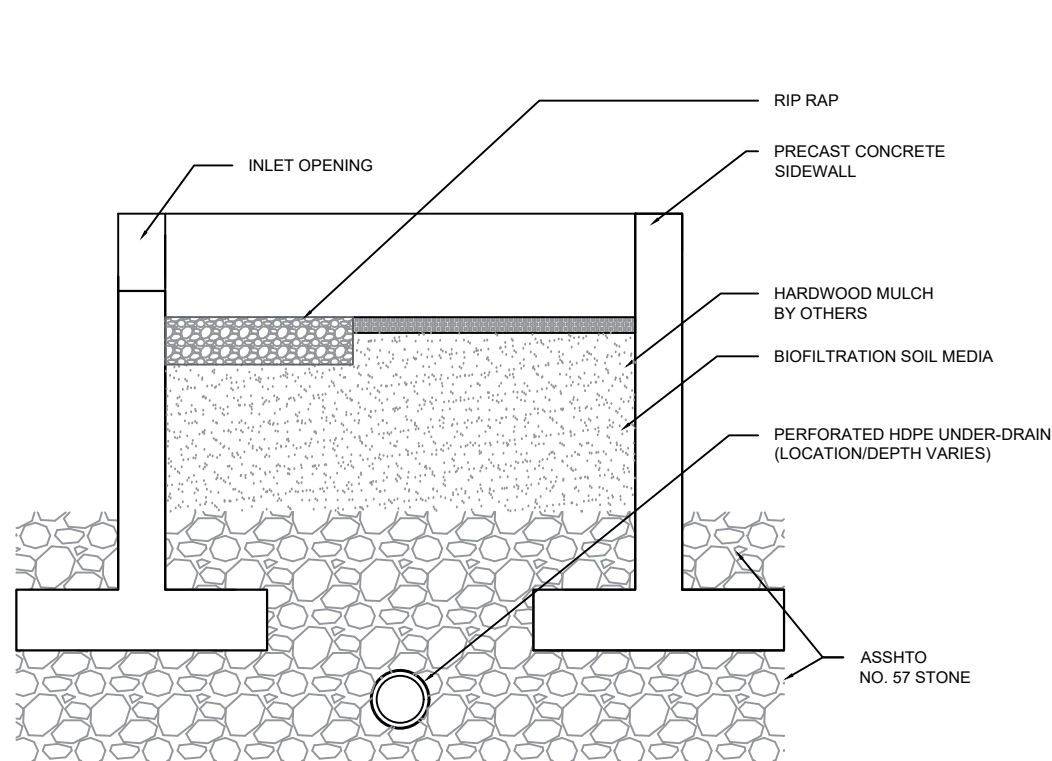

CURB INLET
TYPICAL SECTION

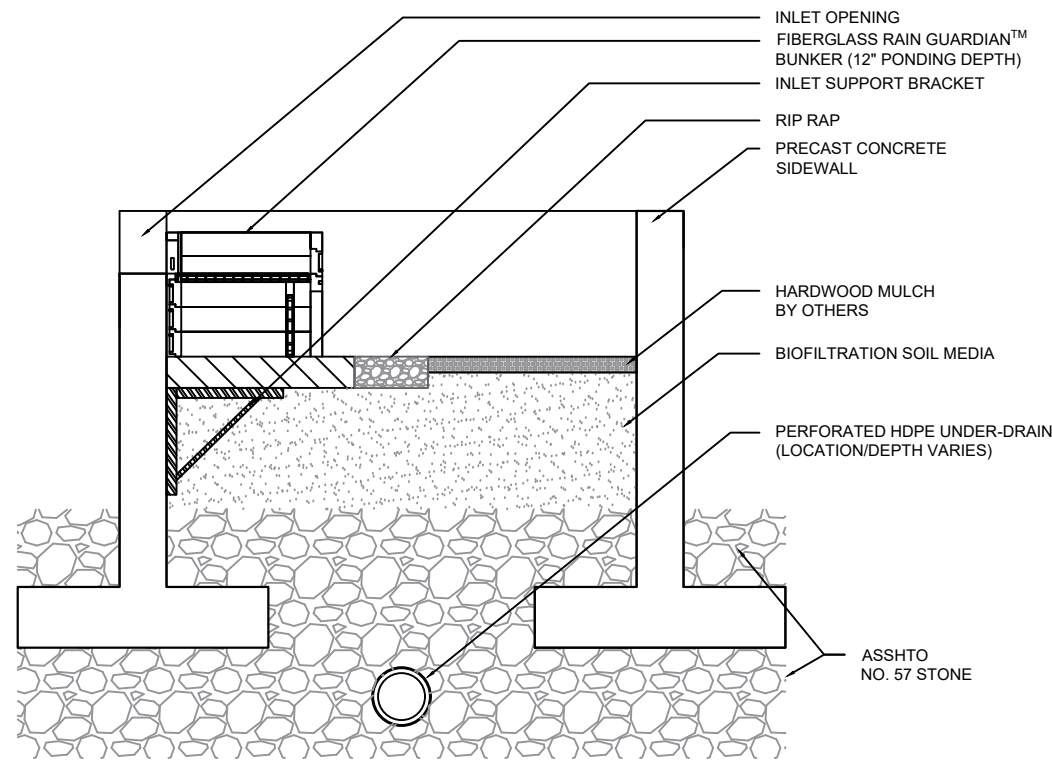

URBAN RAINGARDEN WITH FIBERGLASS RAIN GUARDIAN BUNKER INLET
TYPICAL SECTION

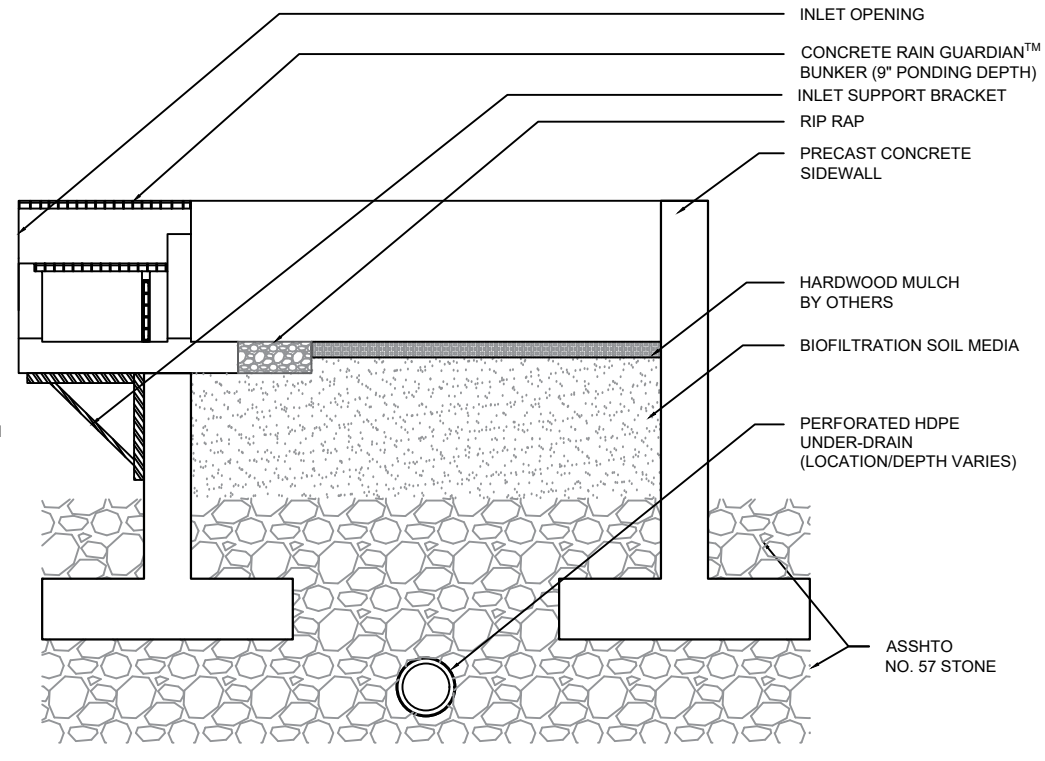

URBAN RAINGARDEN WITH CONCRETE RAIN GUARDIAN BUNKER INLET
TYPICAL SECTION

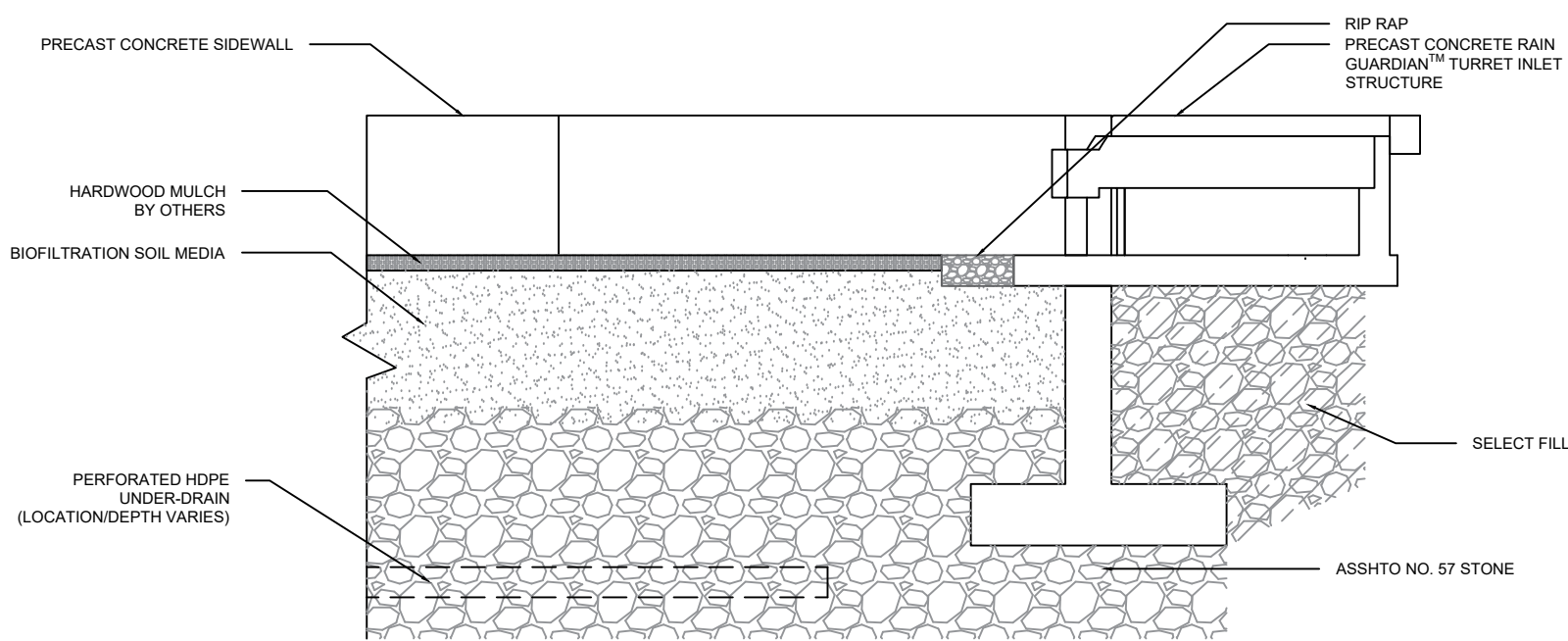

URBAN RAINGARDEN WITH END INLET RAIN GUARDIAN TURRET
TYPICAL SECTION

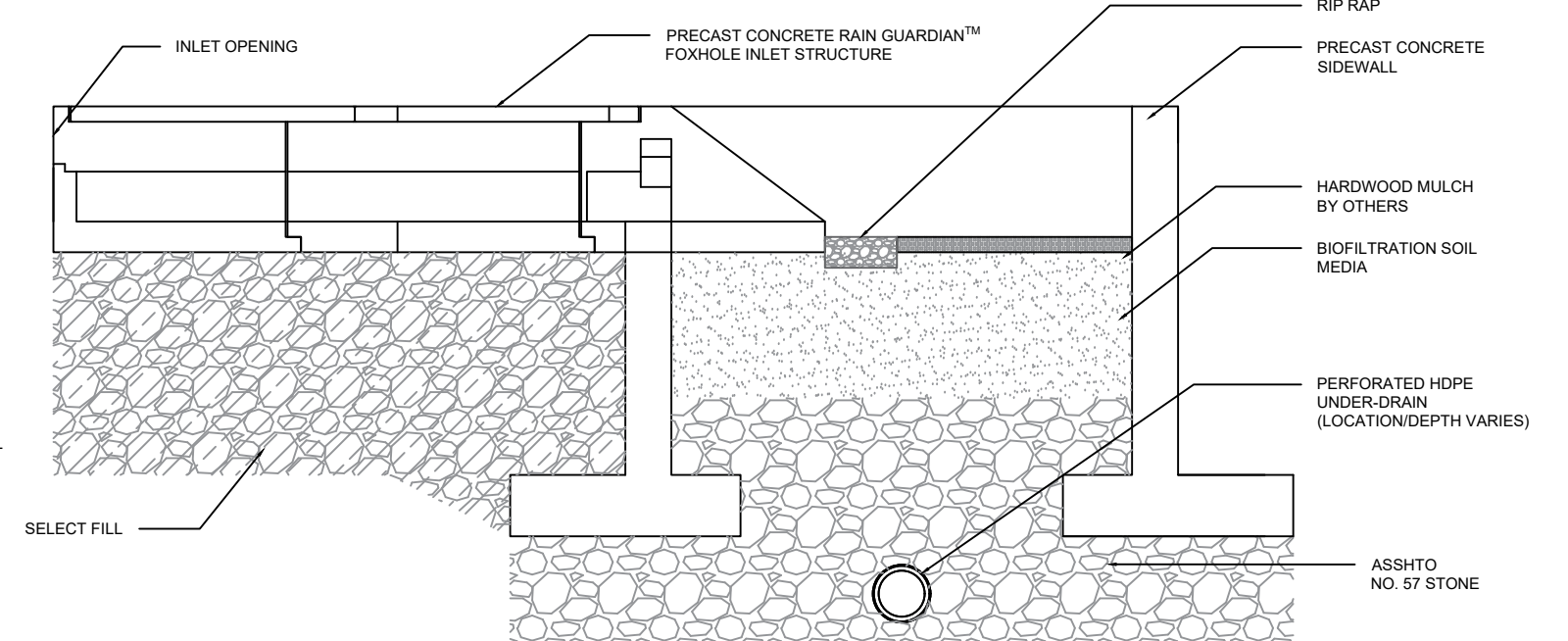

URBAN RAINGARDEN WITH RAIN GUARDIAN FOXHOLE INLET
TYPICAL SECTION

STORMCRETE
When it Rains...it's Porous™
www.stormcrete.com

888.357.1161
www.stormcrete.com
Porous Technologies, LLC
163 Thadeus Street
South Portland, ME 04106
STORMCRETE® PATENT PENDING

URBAN RAINGARDEN

DATE:	04/26/2021
DRAWN BY:	TJC
CHECKED BY:	KJM
SCALE:	NTS

INLET OPTIONS

DWG NO.
D2

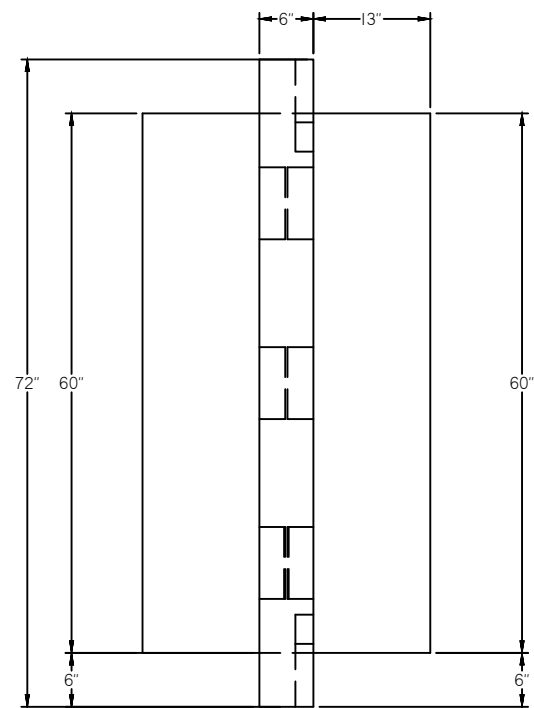

6FT LONG URBAN RAINGARDEN WALL
PLAN VIEW

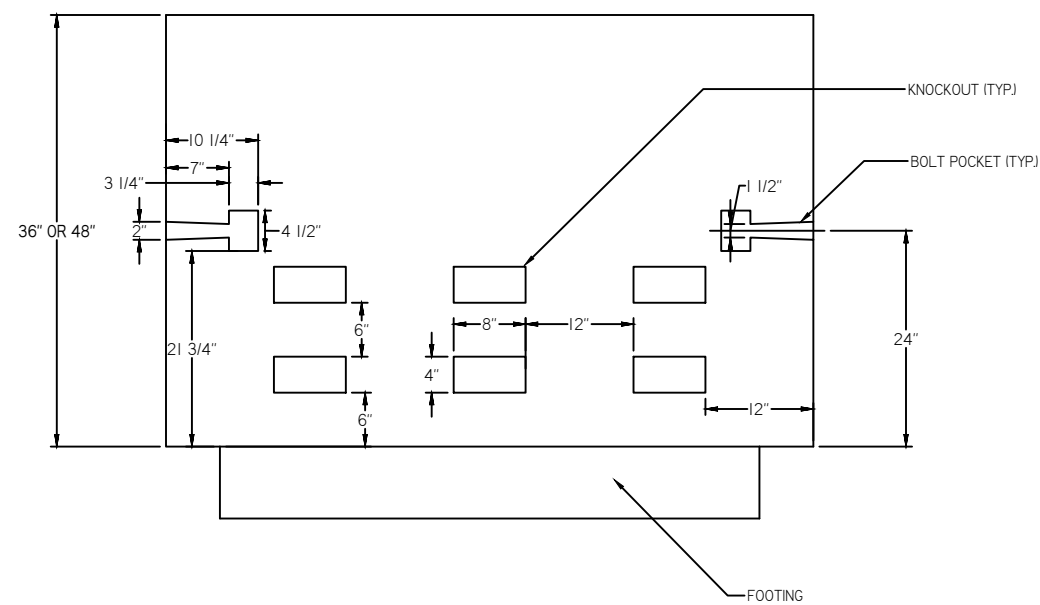

6FT LONG URBAN RAINGARDEN WALL
ELEVATION VIEW

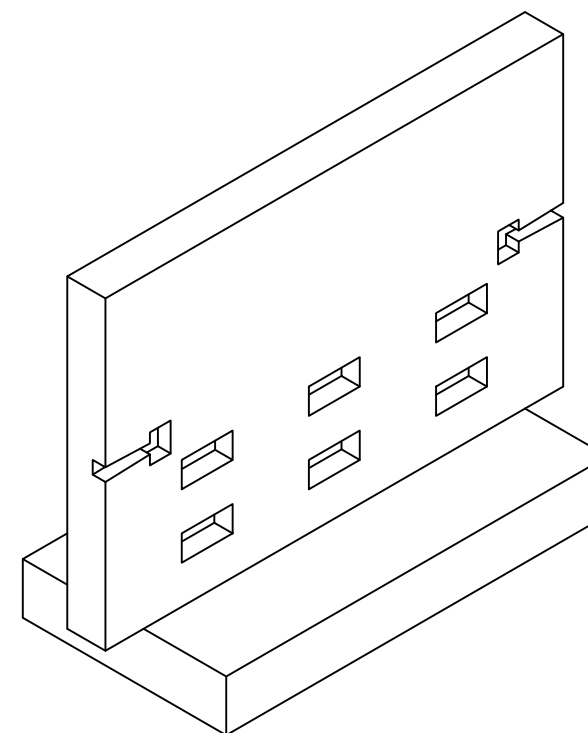

6FT LONG URBAN RAINGARDEN WALL
ISOMETRIC VIEW

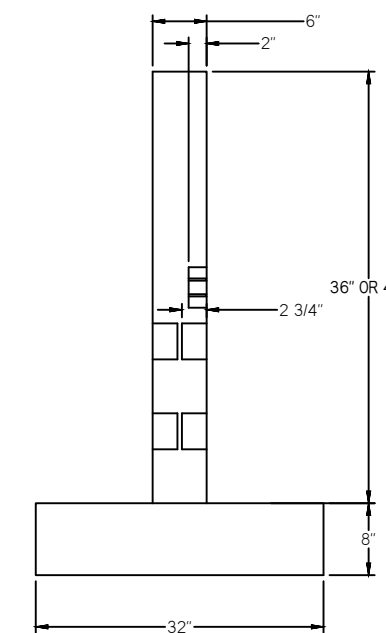

URBAN RAINGARDEN SIDEWALL
ELEVATION VIEW
(TYPICAL)

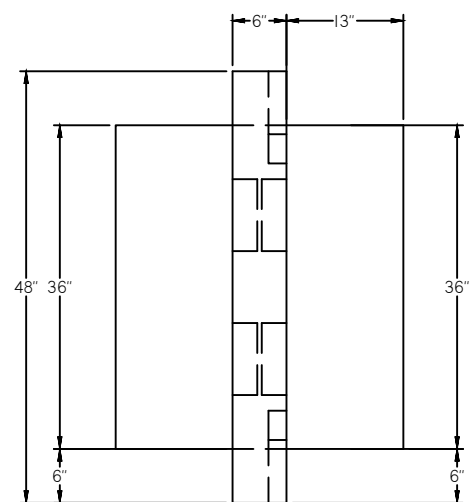

4FT LONG URBAN RAINGARDEN WALL
PLAN VIEW

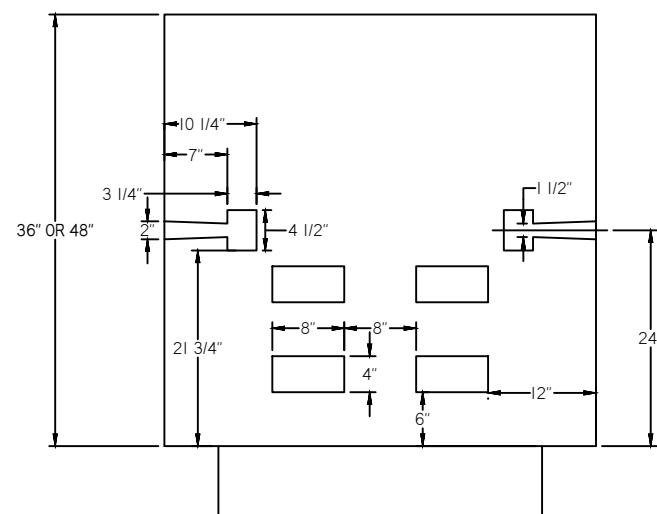

4FT LONG URBAN RAINGARDEN WALL
ELEVATION VIEW

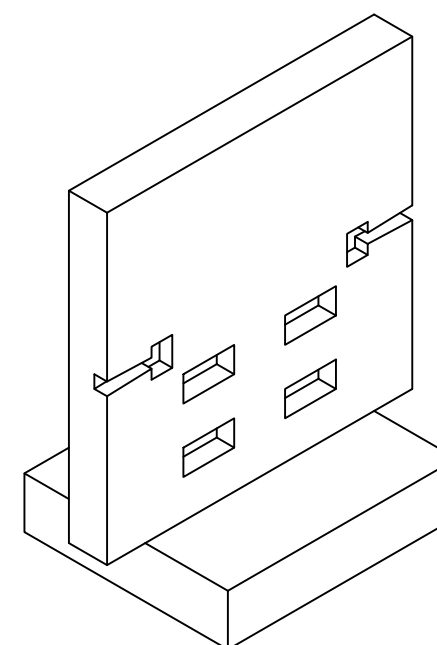

4FT LONG URBAN RAINGARDEN WALL
ISOMETRIC VIEW



888.357.1161
www.stormcrete.com
Porous Technologies, LLC
163 Thadus Street
South Portland, ME 04106
STORMCRETE® PATENT PENDING

URBAN RAINGARDEN

DATE: 04/26/2021
DRAWN BY: TJC
CHECKED BY: KJM
SCALE: NTS

WALL DETAIL

DWG NO.

D3

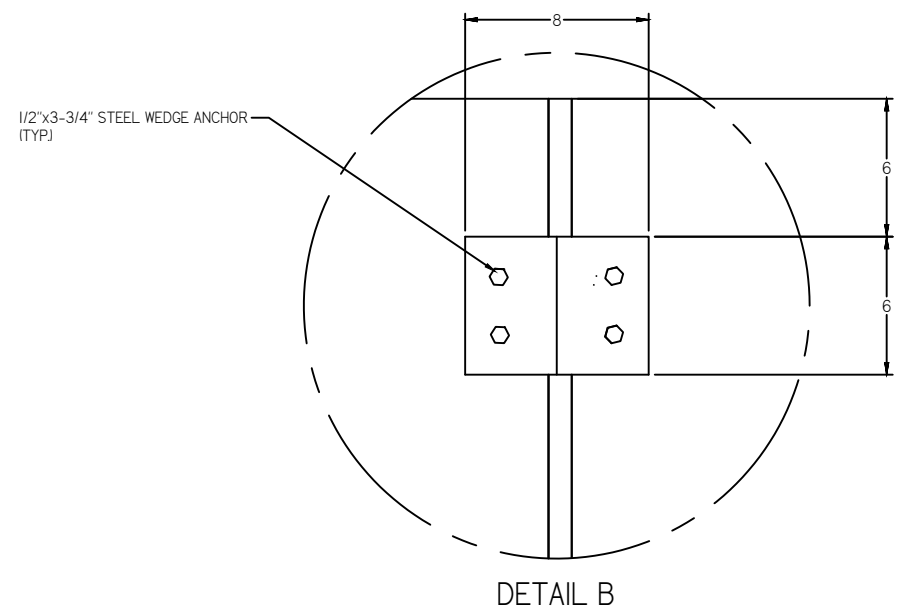
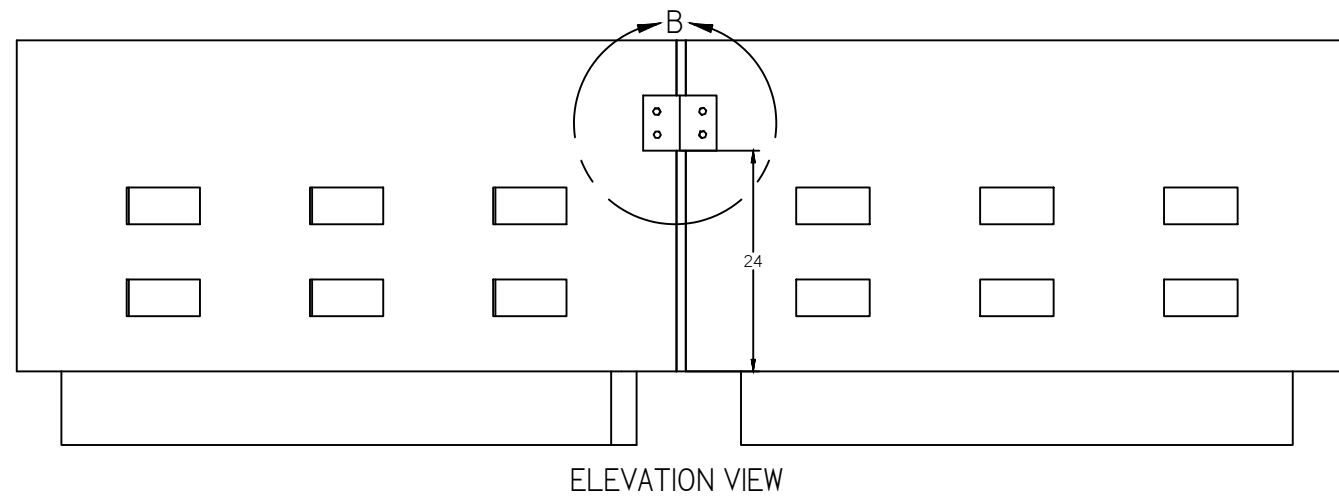
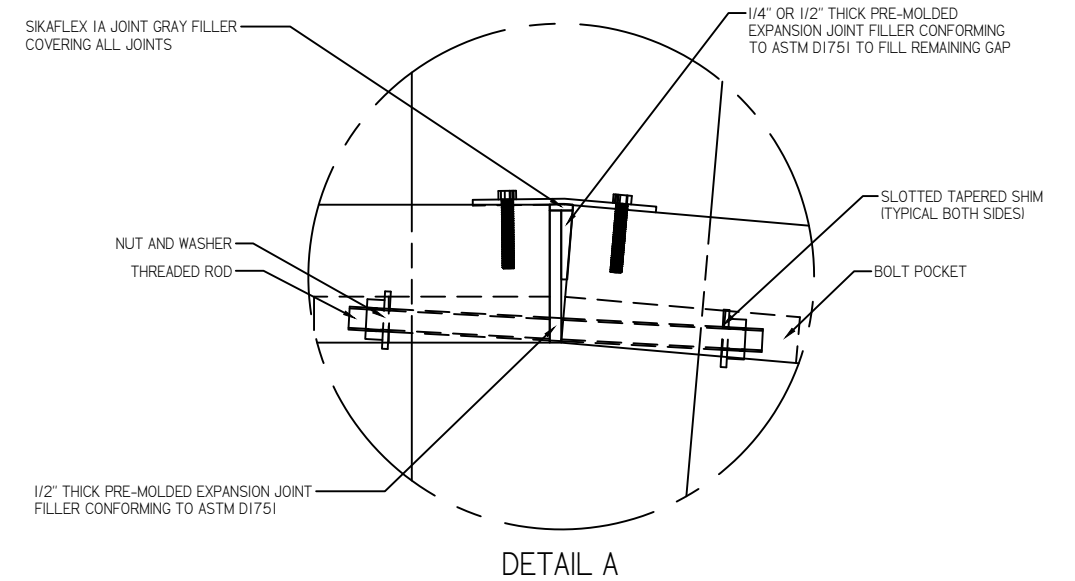
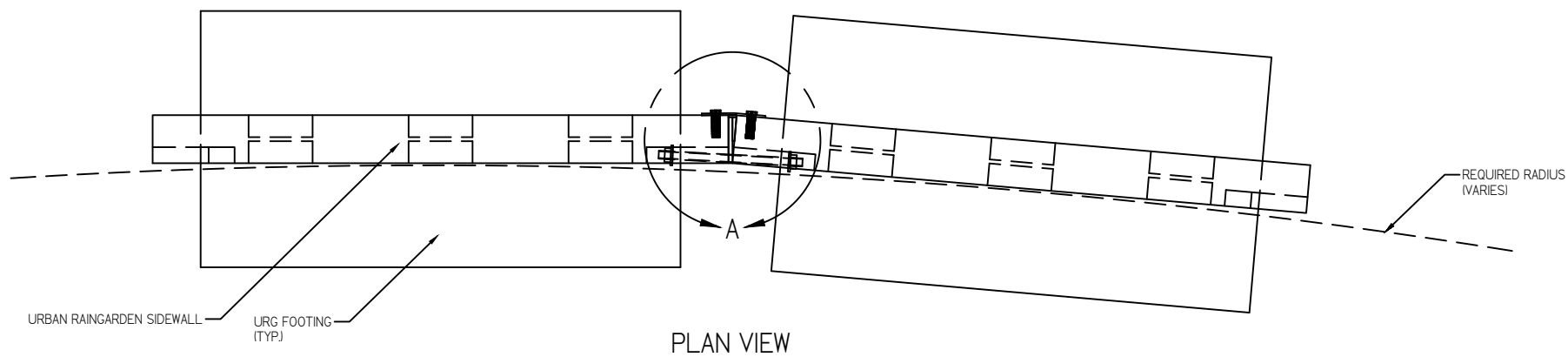

NOTE: BRACKET, THREADED ROD, WASHERS, NUTS, SHIMS PROVIDED BY POROUS TECHNOLOGIES, LLC (EXPANSION JOINT, AND SIKAFLEX PROVIDED BY OTHERS)



888.357.1161
www.stormcrete.com
 Porous Technologies, LLC
 163 Thadeus Street
 South Portland, ME 04106
 STORMCRETE® PATENT PENDING

URBAN RAINGARDEN

DATE: 04/26/2021
 DRAWN BY: TJC
 CHECKED BY: KJM
 SCALE: NTS

WALLS PLACED ON RADIUS DETAIL

DWG NO.
D4

OPTIONAL BEEHIVE OUTLET
WITH OPTIONAL FILTER
(SIZE AND LOCATION VARIES)

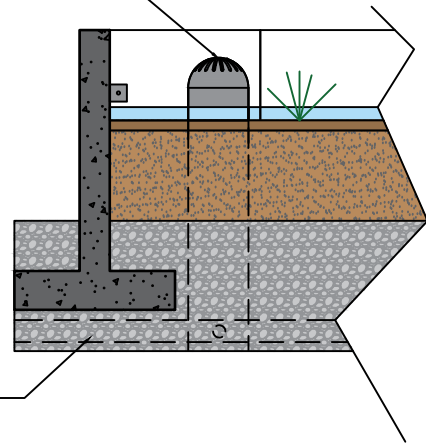

PERFORATED UNDERDRAIN PIPE
(DEPTH VARIES)

BEEHIVE OUTLET WITH UNDERDRAIN SECTION

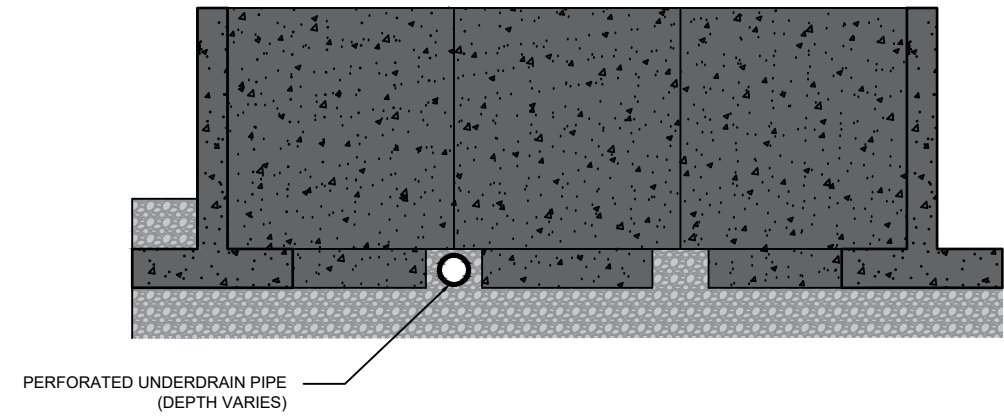

PERFORATED UNDERDRAIN PIPE
(DEPTH VARIES)

UNDERDRAINED SYSTEM SECTION

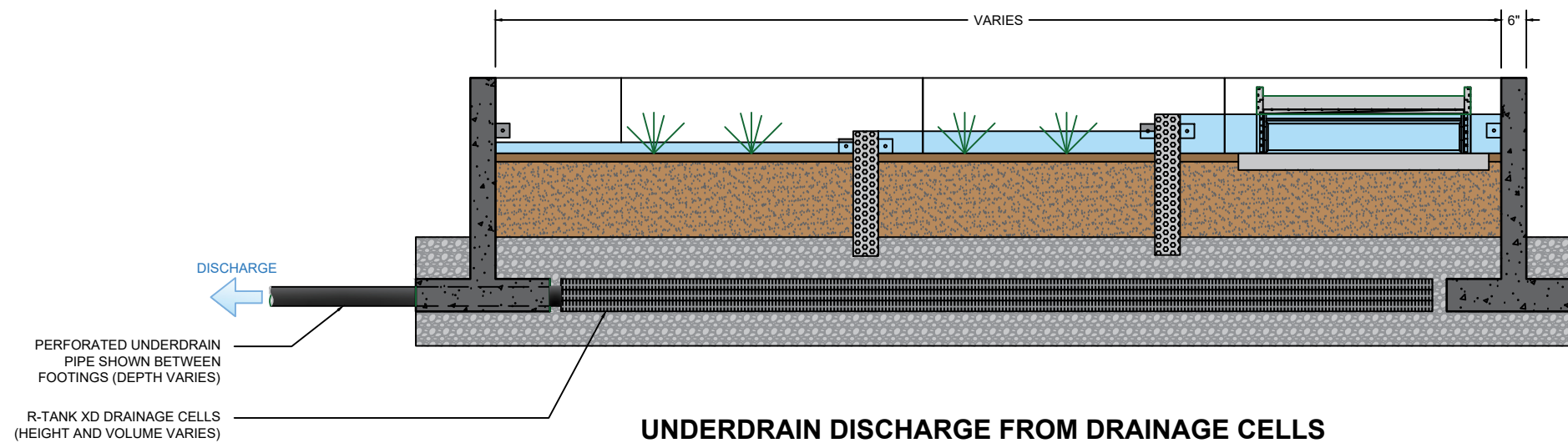

DISCHARGE

PERFORATED UNDERDRAIN PIPE SHOWN BETWEEN FOOTINGS (DEPTH VARIES)

R-TANK XD DRAINAGE CELLS (HEIGHT AND VOLUME VARIES)

UNDERDRAIN DISCHARGE FROM DRAINAGE CELLS SECTION



888.357.1161
www.stormcrete.com
Porous Technologies, LLC
163 Thadeus Street
South Portland, ME 04106
STORMCRETE® PATENT PENDING

URBAN RAINGARDEN

DATE: 04/26/2021
DRAWN BY: TJC
CHECKED BY: KJM
SCALE: NTS

OUTLET OPTIONS

DWG NO.
D5